

PERFORMANCE OF A 6.4 GHz ECR ION SOURCE AT VECC

G. S. Taki, D. K. Chakraborty, P. S. Chakraborty, S. Ghosh, V. Singh,
C. Mallik and R. K. Bhandari

Variable Energy Cyclotron Centre, Department of Atomic Energy
Block-AF, Bidhannagar, Kolkata-700 064, India

Abstract

The 6.4 GHz Electron Cyclotron Resonance Ion Source has been put into continuous operation for injecting remarkably stable oxygen and neon beams to the cyclotron since 1997. The effect of aluminum oxide coating on the high charge state ion production for VEC-ECR was studied, very recently. It was noticed that this process enhanced the currents for multiply charged heavy ions. With aluminized plasma chamber VEC-ECR can produce $12 \mu\text{A}$ of O^{7+} , $6.5 \mu\text{A}$ of Ar^{12+} , $1.5 \mu\text{A}$ of ${}_{86}\text{Kr}^{20+}$ and $1.0 \mu\text{A}$ of ${}_{132}\text{Xe}^{30+}$.

1 INTRODUCTION

A two stage 6.4 GHz ECR ion source was developed in VECC a few years ago [1]. It has travelled through several modifications based on magnetic topology [2,3], external supply of cold electrons [4,5] and microwave feed to improve the performance. Based on the experience in other laboratories [6,7] we studied the effect of aluminium oxide coating as internal electron donor. The high charge state performance of VEC-ECR has been further enhanced by this aluminum oxide coating on the plasma chamber wall. Now, it requires comparatively less microwave power to deliver high charge state ion beam. The long term stability of ion current has been improved remarkably.

2 DESCRIPTION

At present, VEC-ECR is a single stage ion source equipped with a negatively biased electron repeller placed on the axis near the injection mirror point (Fig. 1). It has basically two sets of axial coils, isolated by 25 mm thick soft iron plates [8]. The mirror ratios at the injector and extractor mirror points are 6 and 4.5 respectively with a minimum field of 1.1 kGauss. The radial field remains at 3.4 kGauss on the chamber wall which is planned to be upgraded by replacing with a stronger sextupole assembly. The use of low mass mixing gas gives very good result to produce high charge state. The supply of cold electrons from aluminium plasma electrode and biased electron repeller substantially enhanced the performance of the source.

The ratios of mixed-gas to feed-gas varies from 3 to 8 for different ions. The mixing ratio and bias voltage basically depend upon the charge state of a particular

element. The typical value of negative voltage applied to electron repeller lies between 50 to 100 volts for optimum ion current. The position of the repeller electrode is also very important for peak performance of the source.

As the ion source is now dedicated to injecting beam into the cyclotron, we find very little time to carry out ion source development work. Very recently, we undertook a study of the effect of aluminum coating on the copper plasma chamber wall.

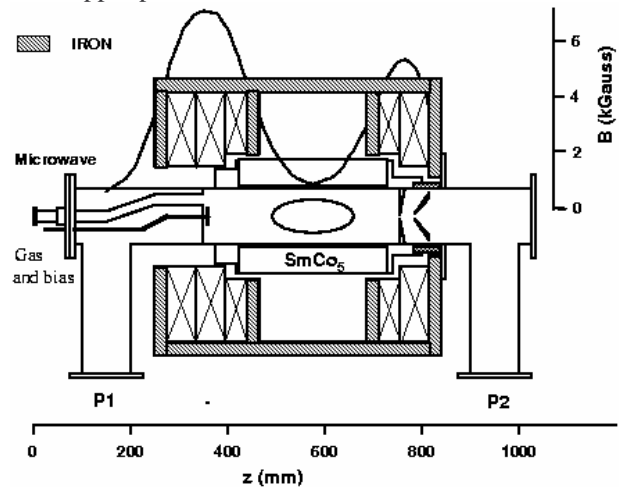

Figure 1: Schematic VEC-ECR

The ECR copper plasma chamber wall is usually coated with Al by vacuum evaporation method. A suitable demountable set-up has been fabricated for applying a coating, periodically, on the inner wall of the copper plasma chamber. We followed the vacuum evaporation method using a tungsten filament heated by an external power source.

Initially, the plasma chamber wall was coated with Al and the Al film was then allowed to get exposed to pure oxygen for a few hours to develop layers of Al_2O_3 .

After this process, beams of different gases were tried systematically. A drastic improvement in intensity and stability was observed in all the cases. It was noticed that this process enhanced the ion currents almost by an order of magnitude for higher charge states. The effect of negatively biased electrode remained unchanged but the gas mixing was found to be no more effective. However, in the case of higher charge states of Xenon a small amount of mixing gas was found to be helpful.

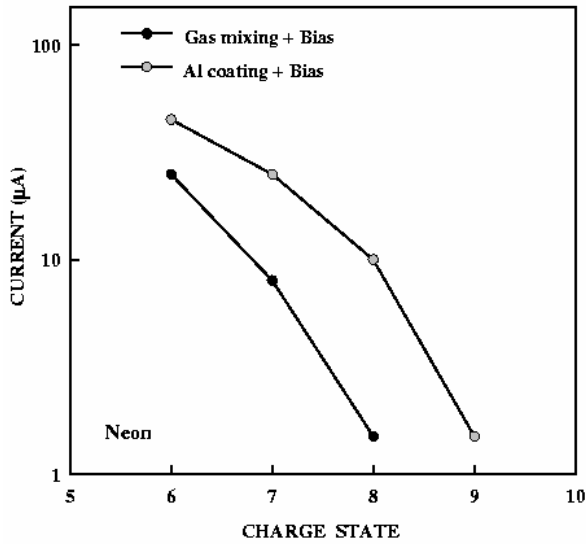

Figure 2: Charge state distribution of oxygen

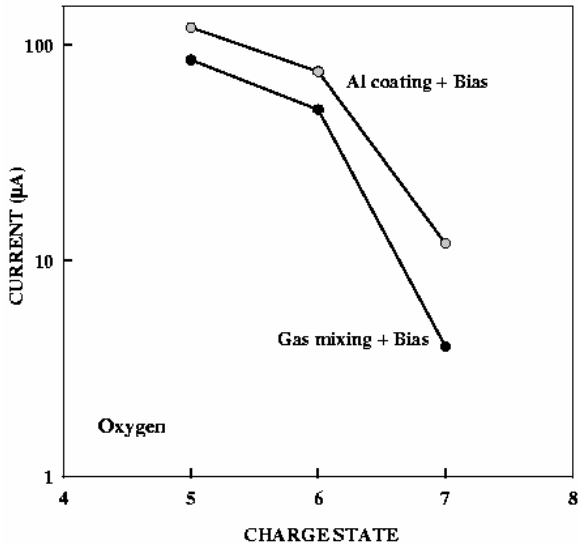

Figure 3: Charge state distribution of neon

3 RESULTS

From Fig. 2 and Fig. 3, it is clear that Al deposition shifted the charge state distribution (CSD) of oxygen and neon towards the higher side. As the secondary electron emission coefficient of Al_2O_3 is sufficiently high (≈ 9), this shift of the CSD may be due to the enhanced supply of transverse cold electrons which lowers the ECR plasma potential [6].

Al deposition allows the ECR to operate at a lower neutral pressure and the consumption of sample gases is also very low. During this period we have developed Kr and Xe beam (Table 1) for the first time. With aluminized plasma chamber VEC-ECR produced $1.5 \mu A$ of $^{86}Kr^{20+}$ and $1.0 \mu A$ of $^{132}Xe^{30+}$, which is highly satisfactory.

Table 1: Currents for VEC-ECR in μA

Ion	Cur	Ion	Curr	Ion	Curr
N^{4+}	130	$^{86}Kr^{12+}$	45	Xe^{19+}	4.0
N^{5+}	86	Kr^{13+}	20	Xe^{20+}	4.0
N^{6+}	31	Kr^{15+}	10.6	Xe^{21+}	4.1
O^{5+}	120	Kr^{17+}	9	Xe^{22+}	2.6
O^{6+}	75	Kr^{18+}	8.5	Xe^{23+}	3.6
O^{7+}	12	Kr^{19+}	6.5	Xe^{24+}	2.5
Ne^{6+}	45	Kr^{20+}	1.5	Xe^{25+}	2.2
Ne^{7+}	25	$^{84}Kr^{14+}$	15	Xe^{26+}	2.0
Ne^{8+}	10	Kr^{15+}	10	Xe^{27+}	1.9
Ne^{9+}	1.5	Kr^{16+}	6.5	Xe^{28+}	2.0
Ar^{9+}	41	Kr^{17+}	6.0	Xe^{29+}	1.1
Ar^{11+}	11.5	Kr^{19+}	0.5	Xe^{30+}	1.0
Ar^{12+}	6.5	Kr^{20+}	0.3	Xe^{31+}	0.7

All currents are extracted at 10 kV through 8 mm circular aperture and optimized for individual charge states. For Krypton and Xenon, ion currents are measured on the Faraday cup using an image slit of width 5 mm. For the rest of the elements the slit width has been increased to 20 mm.

4 CONCLUSION

For VEC-ECR, the present ∞ -wave window cooling restricts the injected ∞ -wave power up to 600 Watts. Ion currents of high charge states for heavier elements may increase with higher microwave power. Due to the high erosion resistance of Al_2O_3 against plasma etching, the recycling of aluminum deposition is necessary after an interval of 8 to 10 weeks of continuous operation.

REFERENCES

- [1] D.K. Bose, G.S. Taki et. al., Indian J. Phys. **66B** 629(1992)
- [2] G. S. Taki, P. Y. Nabhiraj, R. K. Bhandari and D. K. Bose, Proc. 4th National Seminar on PATPAA, Calcutta(1996).
- [3] T.A. Antaya, S.Gammino, Rev. Sci. Instrum., **65** 1723 (1994)
- [4] G.S. Taki et. al., Proc. DAE Symp. on Nucl. Phys. **35B** (1992)486
- [5] G. Melin et. al., Proc. 10th Int. Workshop on ECR Ion Sources ORNL conf-9011136 (1990)
- [6] Z. Q. Xie and C. M. Lyneis, Rev. Sci. Instrum., **65** 2947(1994)
- [7] T. Nakagawa, T. Kageyama, M. Kase, A. Goto and Y. Yano, Jpn. J. Appl. Phys. **32** 1335(1993)
- [8] G. S. Taki, D. K. Bose et. al., Ind. J. of Pure and Appl. Phys. **39** 41(2001).